

AXOS
340 330 320 310

CLAAS

A true friend
and partner.



It's exactly what we
want.





A true friend and partner, a reliable companion ready to assist in any situation – agility, flexibility, durability and patience are the hallmarks of the AXOS. With its unbounded energy and thirst for action, the AXOS is ready to go to work at a moment's notice. The verdict is unanimous – a truly indispensable machine.

The AXOS from CLAAS.

Taking charge.





The smaller the tractor, the more versatile it needs to be. Particularly in power ranges of up to 100 hp, farmers are looking for a compact machine that can tackle any kind of job encountered on the farm.

With this in mind, CLAAS has developed a tractor that is the product of all our company's diverse expertise and experience. We understand the needs of farmers and operators, and have brought to market a formidable tractor reflecting their hopes and aspirations. You too will be delighted by the result.

Versatile around the farm.

The AXOS is a machine for daily use. With its compact dimensions, it delivers enormous flexibility for a wide variety of jobs. Particularly when used in conjunction with the front loader, the machine demonstrates its formidable strengths and versatility.

Powerful in the field – comfortable on the road.

A whole range of abilities: with its ideal weight distribution and an especially long wheelbase, the AXOS generates enormous tractive power and lift capacity, while delivering a high degree of driving comfort on the road.

Customisable ex factory.

Tailor the AXOS to your exact requirements – CLAAS offers a wide variety of equipment options based on the C, CL and CX models.

A joy to use.





Contents

Versatile around the farm.	8
Cab	10
Dimensions	12
Front loader	14
PTO shaft, hydraulics	18
Powerful in the field – comfortable on the road.	20
Engine	22
Transmission	24
Tractive power and lift capacity	26
Front linkage, front PTO shaft	28
Customisable ex factory.	30
C CL CX models	32
Cab variants	34
Hitching systems	36
Maintenance	38
Service	40
Specifications	42

Versatile around the farm.



Extremely flexible and manoeuvrable:
short overall length and a tight turning circle

Greater stability and longevity:
fully integrated front loader mounting brackets

For increased comfort and greater efficiency:
REVERSHIFT clutchless reverser

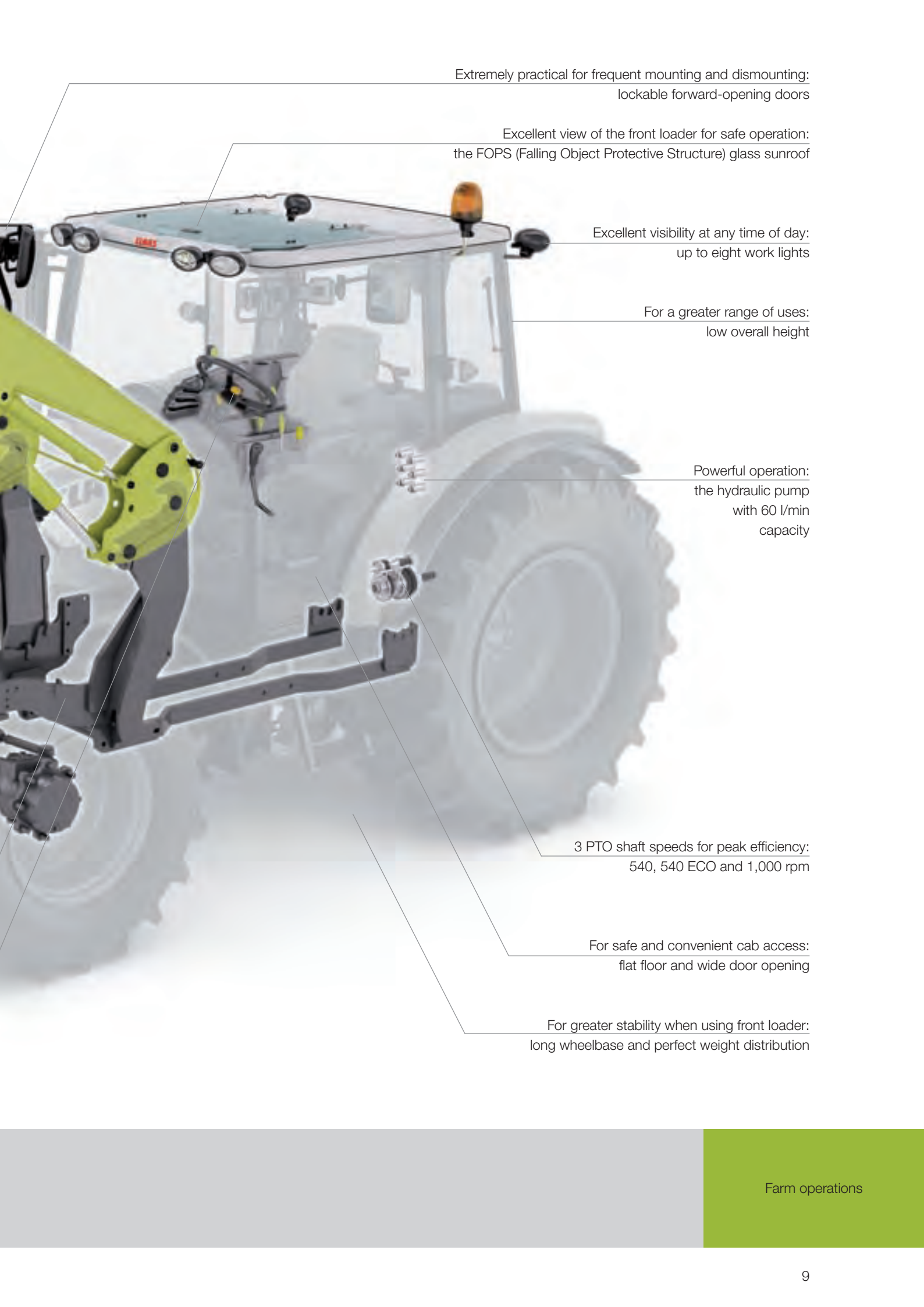

Extremely practical for frequent mounting and dismounting:
lockable forward-opening doors

Excellent view of the front loader for safe operation:
the FOPS (Falling Object Protective Structure) glass sunroof

Excellent visibility at any time of day:
up to eight work lights

For a greater range of uses:
low overall height

Powerful operation:
the hydraulic pump
with 60 l/min
capacity

3 PTO shaft speeds for peak efficiency:
540, 540 ECO and 1,000 rpm

For safe and convenient cab access:
flat floor and wide door opening

For greater stability when using front loader:
long wheelbase and perfect weight distribution



Make yourself at home.

The AXOS's spacious and comfortable cab has been specifically developed for mixed farms. Wide-profile, forward-opening doors, solid handles and self-cleaning steps facilitate easy access to the cab throughout the day.

Doors locked open.

Pleasant and stress-free operation is yet another benefit of the AXOS. Each cab door can be opened to the front (by 180°) and locked into position, facilitating rapid access to the cab where frequent mounting and dismounting is required. Since the doors do not protrude beyond the width of the tractor, you can be assured of absolute safety at all times.

Focus on the important issues.

The AXOS is extremely intuitive to operate, and is therefore ideal for inexperienced drivers as well. The ergonomically arranged operating controls are fully accessible from the driver's seat (with optional air suspension).

What's more, the clear dashboard arrangement allows you to concentrate on what's happening outside. The large glass panels ensure outstanding all-round visibility, and with up to eight work lights you can continue to work safely and efficiently when night falls.



Practical throughout the day: the AXOS's lockable, forward-opening doors.



Air conditioning is available in each cab version.



Compact on the outside – spacious inside.

Unrivalled benefits for AXOS operators:

- Excellent all-round visibility, thanks to the spacious cab and large glass panels
- Forward-opening windscreen for a perfect view of the working area
- Efficient air-conditioning system for high productivity
- Lockable, forward-opening doors do not protrude beyond the tractor width
- Greater comfort, thanks to the flat cab floor (including for the low-roof version)
- Simple, intuitive operation, ideal for less experienced drivers as well
- All information in clear view on the easy-to-read dashboard
- Low noise level for relaxed operation
- Up to eight work lights for excellent visibility in the dark

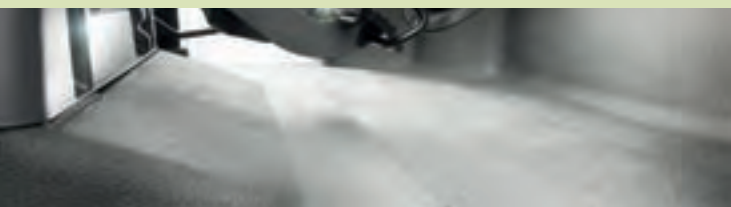

Safe and convenient cab access, thanks to spacious entrance and flat cab floor.

Cab

Nowhere off limits.

Compact and convenient.

Thanks to its low overall height, the AXOS is also perfectly suited to operations in farm buildings with low roofs and entrances. Despite the tractor's compact external dimensions, the AXOS is well endowed with interior space. Even in the low-roof version, tall operators enjoy ample headroom.

AXOS cab version heights:

- High roof: 2.61 m (with 30" tyres)
- Low roof: 2.46 m (with 30" tyres)
- Platform: 1.95 m (roll bar retracted, 30" tyres)



Perfect weight distribution.



Short overall length
– long wheelbase.



Nimble and productive.

The tight turning radius of just 4.3 metres and short overall length of the AXOS ensure quick and convenient operations in even the most confined spaces. No unnecessary manoeuvring – enabling you to boost your productivity and efficiency accordingly.

Tractive power with stability.

The long wheelbase (2.49 metres), low centre of gravity and balanced weight distribution deliver tangible benefits in day-to-day operations. These include an incredibly high standard of driving comfort and a remarkable degree of stability, particularly when using the front loader. The AXOS unleashes its full tractive power even without additional ballasting at the rear.

Benefits of the compact AXOS design:

- Low overall height and tight turning radius for greater versatility and manoeuvrability
- Long wheelbase for greater stability and a firm hold on the road
- Excellent manoeuvrability, thanks to short overall length
- Optimal weight distribution delivers greater tractive power and lift capacity



Pivoting front mudguards allow maximum steering angles.

Dimensions



A powerful combination.

The AXOS is extremely robust in combination with the CLAAS front loader. The front loader mounting bracket is connected to the AXOS along the entire length of the tractor, right up to the rear axle, enabling mechanical stresses to be transferred to the tractor uniformly, even when performing difficult loading operations.

A convenient and timesaving design – all maintenance points remain in easy reach with the front loader deployed. The outstanding view of the implements and full working area of the front loader enable the operator to work productively and accurately.

Precise operation.

Regardless of which of the two operating systems you choose, accuracy and ease of use remain defining characteristics of AXOS front loader operation.

You can choose between:

- PROPILOT with mechanical single-lever control.
- FLEXPILLOT with maintenance-free, hydraulic low-pressure system and single-lever control.

Quick attachment and removal.

The AXOS is ready for deployment in next to no time, with or without front loader.

- The FITLOCK coupling system makes rapid attachment and removal of the front loader a breeze.
- The MACH quick coupler enables all hydraulic and electrical lines to be connected with just a simple hand movement, even when they are under pressure.



The front loader mounting bracket transfers mechanical forces across the entire implement frame, facilitating the most demanding front loader operations.

Finished in no time.

The combination of AXOS and the CLAAS front loader delivers tangible benefits:

- Attachment and removal without tools
- The special design of the front loader mounting bracket enables the loader to be pushed to the absolute limit
- The outstanding view of the implements ensures precise operation
- Two convenient operating control variants to choose from: PROPILOT and FLEXPILOT
- Quick and straightforward tractor maintenance, thanks to unrestricted access to all service points



Thanks to the FITLOCK and MACH couplers, you need to dismount only once when attaching or removing the front loader.

CLAAS front loader

Everything in view – everything to hand.

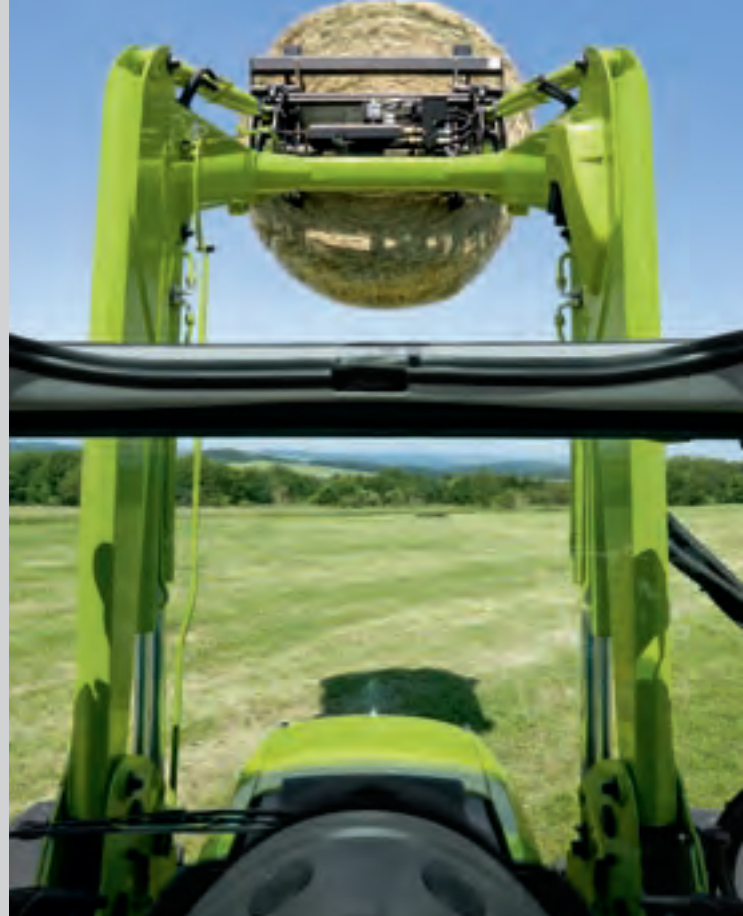

Let nothing escape your notice.

AXOS operators enjoy a perfect view of the attached implements and entire working area. The CLAAS front loader is renowned for its slender frame and hydraulic lines integrated into the arms, leaving no disruptive cross braces to restrict your field of vision.

The highly sophisticated design guarantees safe working operations and rapid loading cycles. What's more, the well-protected and easily accessible lubricating nipples greatly facilitate routine maintenance tasks.

Transform your CLAAS tractor into a versatile all-purpose machine.

A huge range of high-performance attachments are available for use with the CLAAS front loader. The entire range is rooted in the practical experience of professional operators, and has been specially developed with farmers' day-to-day activities in mind.

AXOS	FL 100	FL 80	FL 60
340	●	●	–
330	●	●	–
320	●	●	–
310	–	●	●
Lifting capacity kg	2,190	1,890	1,250
Lifting height m	4.00	3.85	3.75

● Standard – Not available





Always a smooth ride.

SHOCK ELIMINATOR, the vibration dampening system for CLAAS front loader models, protects the operator, tractor and front loader itself. The built-in nitrogen accumulator reliably reduces impacts, jolts, shocks and vibrations.



The benefits for you:

- Excellent view of attachments, thanks to the compact design and supply lines integrated into the frame members.
- Perfect view of the front loader, thanks to the FOPS (Falling Object Protective Structure) glass sunroof.
- Vibration dampening for increased driving comfort.
- Wide choice of implements for a huge range of deployment options.



Front loader range
Front loader implements



The perfect engine speed for every application.

The AXOS delivers up to three PTO shaft speeds for a range of day-to-day operations:

- 540 rpm ECO for lighter equipment such as a tedder or swather.
- 540 rpm standard.
- 1,000 rpm for heavy applications such as a feed mixer or rotary harrow.

Whether deploying a fertiliser spreader or mower, the PTO shaft is engaged smoothly, regardless of the implement attached – with either mechanical or hydraulic action.

The perfect solution for every hydraulic requirement.

With a flow rate of 60 l/min, the hydraulic pump can meet any requirement. Up to three mechanical spool valves can be attached with optional equipment.

Operation is via either a single lever or a 4-way control lever located conveniently on the right-hand side console. The spool valves feature lock-up units, kick-out function and flow controller with flow-rate function. You have the option of switching between single and double-acting functions.





Flexibility is everything.

AXOS benefits:

- Increased flexibility, thanks to three PTO shaft speeds
- Wide selection of spool valves and functions
- Hydraulic connections with oil spillage receptacle
- Tidy design at the rear



The PTO shaft stub can be quickly changed (dry state) by removing six bolts, enabling the AXOS to power a huge variety of attachments.

PTO
Hydraulics

Powerful in the field – comfortable on the road.

Greater relaxation on the job,
thanks to low noise level

High torque in every speed range:
torque rise up to 43 %

Perfect for front attachments:
integrated front hydraulic system and
front PTO shaft

Up to 20 gears forward and reverse, with additional
30F/30R creep gear, for the ideal speed every time

Long wheelbase and excellent weight distribution
for high tractive power and excellent driving comfort

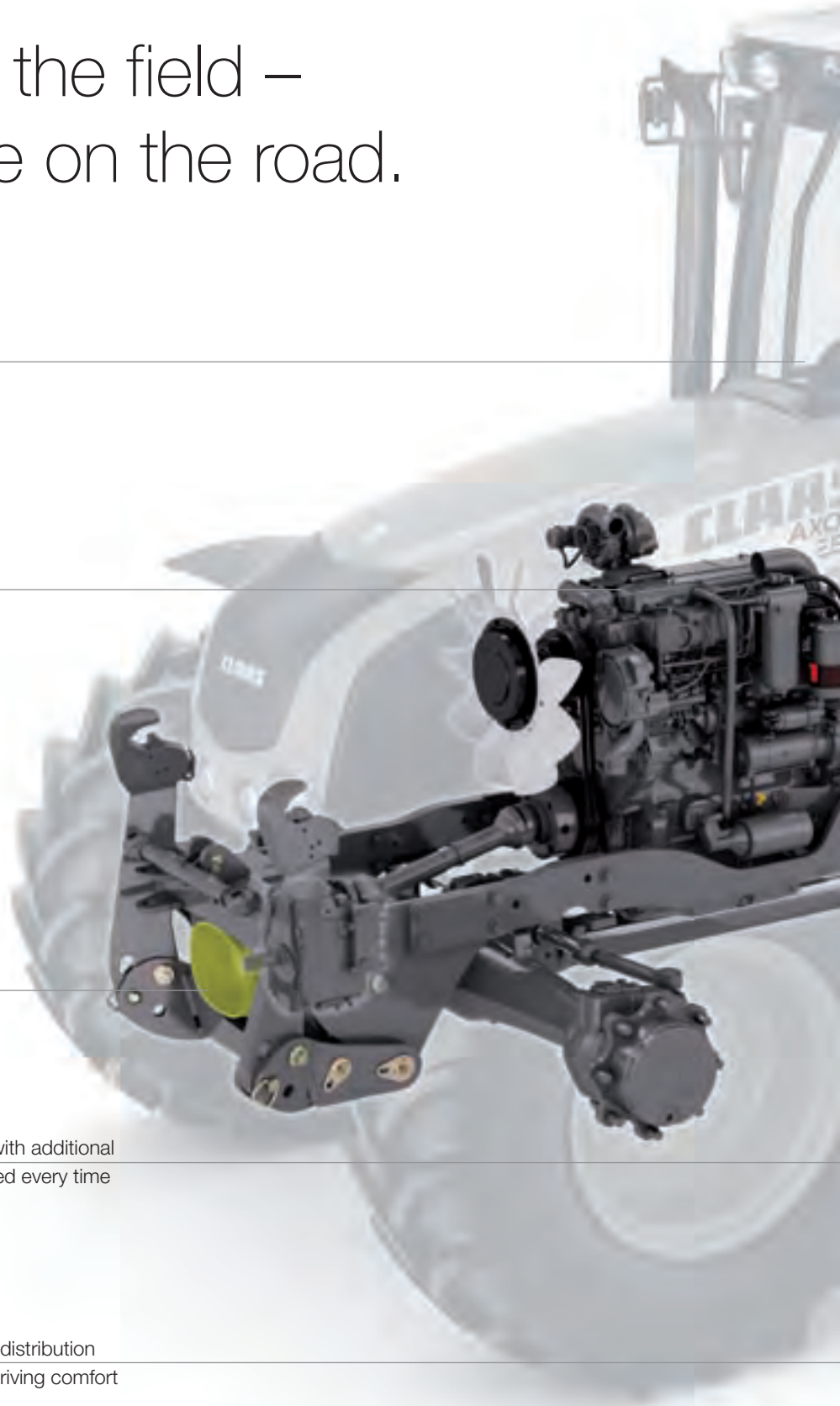

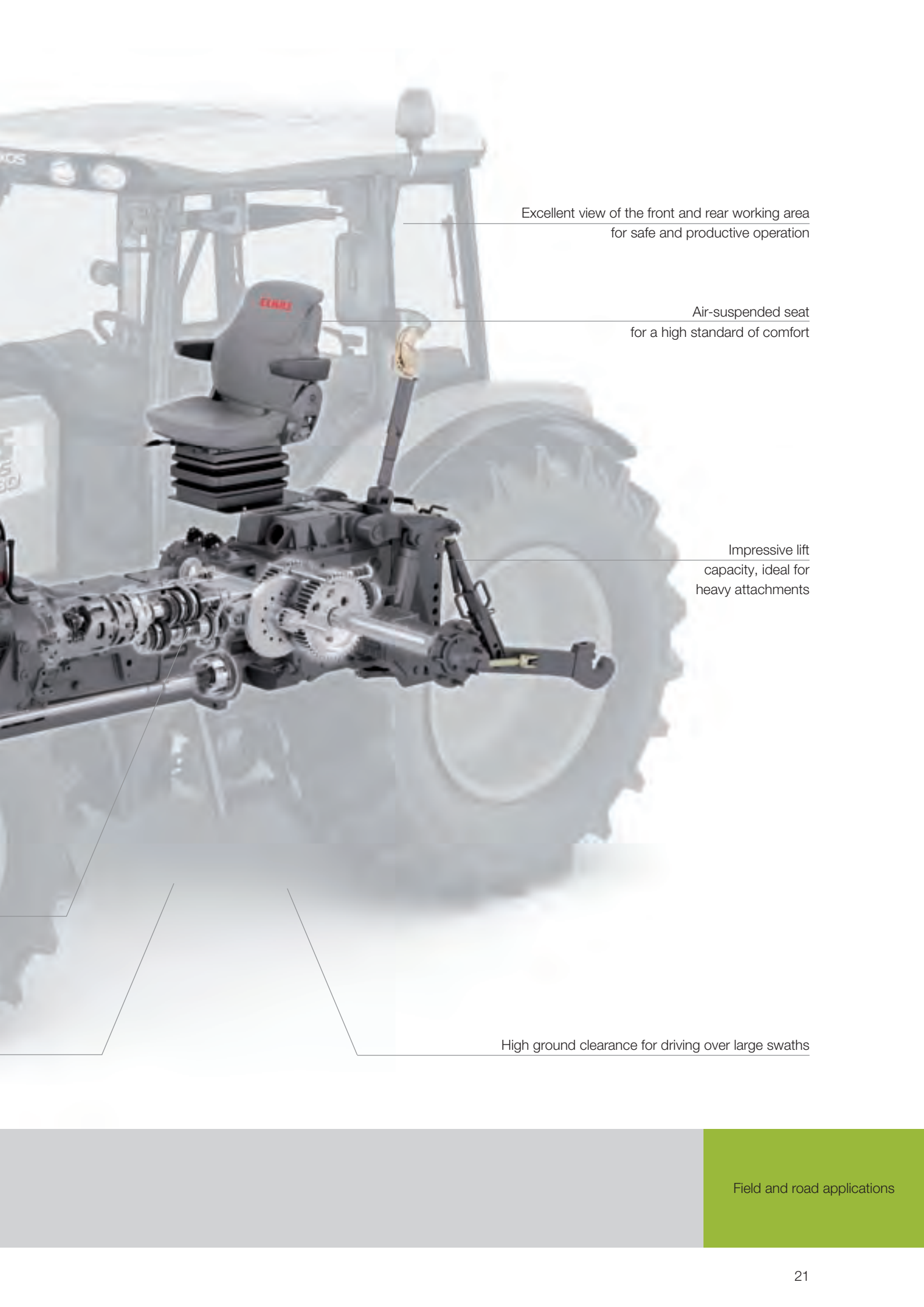

Excellent view of the front and rear working area for safe and productive operation

Air-suspended seat for a high standard of comfort

Impressive lift capacity, ideal for heavy attachments

High ground clearance for driving over large swaths

Field and road applications

Save on refuelling time.

Powerful and reliable.

Whether at full or partial throttle, the AXOS works with maximum efficiency and low fuel consumption. Thanks to the machine's large fuel tank, very long working days are possible without the need to refuel.

The latest generation of Perkins engines has been developed on the basis of tried-and-tested components to deliver an extremely high standard of reliability and power, including, for instance, mechanical injection, intercoolers and turbochargers. Through the internal exhaust gas recirculation system, the AXOS, with its TIER 3 engine, also meets environmental standards.





The power to impress.

The 74- to 100-hp, 4.4-litre, four-cylinder turbo units always deliver superb performance with dynamic power reserves.

The constant power range of up to 300 rpm with a torque rise of 40 percent guarantees a powerful engine output in any engine speed range. This means that you're always saving fuel while under way, especially given that many applications allow you to drive at a reduced engine speed.

AXOS 330

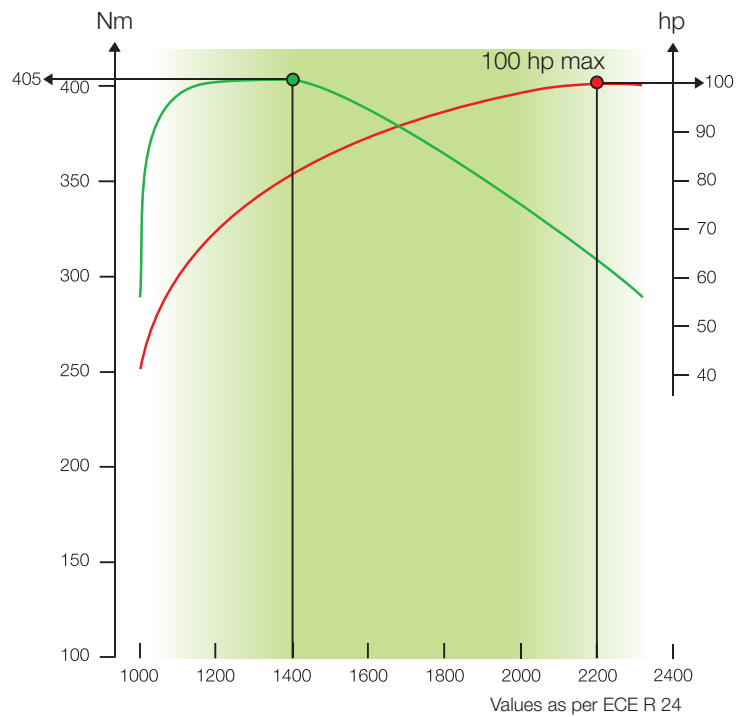

Engine



Five transmission options.

Choose the AXOS that is right for you:

AXOS C – basic model, mechanically operated:

- Fully mechanical 10F/10R
- Fully mechanical 20F/20R (with mechanical splitter)

AXOS CL – front loader specialist with REVERSHIFT:

- Transmission with REVERSHIFT 10F/10R electrohydraulic reversing function

AXOS CX – premium model with wide-ranging applications:

- Transmission with REVERSHIFT electrohydraulic reverser function and TWINSHIFT 20F/20R two-stage powershift

Always the right gear.

The 20F/20R transmission variants provide 12 ratios between 2 and 15 km/h in the main working range, enabling you to adjust your speed to suit the circumstances perfectly.

A creep gear with minimal speed from 0.44 km/h (with 30F/30R transmission) is available for all transmission variants, augmenting the AXOS's range of applications.

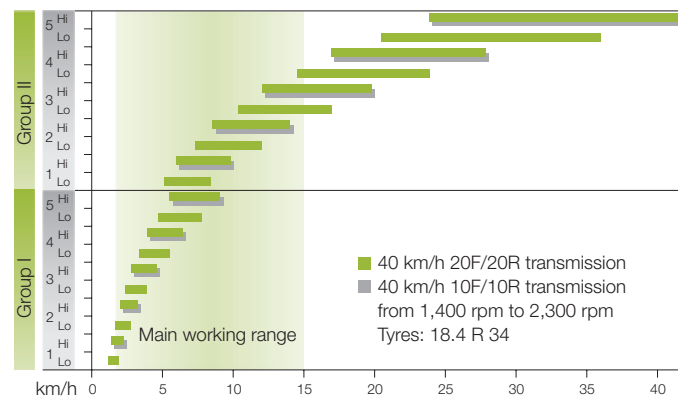

The TWINSHIFT function is pushbutton-operated via the shift lever. The activated level can be read off the instrument panel.



Change gears as you see fit.



With REVERSHIFT, you can forget about the clutch pedal.

1. REVERSHIFT lever for quick turning manoeuvres, ideal during front loader operations.



2. Clutch button on the shift lever for convenient gear changing on the road.



A design of pure genius.

The AXOS, a simple yet sophisticated design: 50/50 weight distribution and an exceptionally long wheelbase enable the machine to generate high levels of tractive and lifting power while enhancing comfort on the road, even with heavy implements fitted.

The exemplary design facilitates operation with reduced front ballasting while delivering a maximum continuous lift capacity of 3,800 kg (measured at 610 mm), with numerous benefits for the operator, including increased load capacity and reduced fuel consumption.

Intelligent control.

A mechanical and an electronic control system (TCE 9) are available for operating the linkage. The TCE 9 system is characterised by an array of impressive functions and benefits to greatly facilitate day-to-day operations, including vibration dampening, rapid intake and lift-height limiter. The operating implements are precision-controlled by the TCE 9 system, and a high standard of on-road comfort is guaranteed.

Convenient linkage operation.

In both operating variants, the linkage can be controlled externally. With TCE 9, for instance, the rear linkage is operated via two pushbuttons on the mudguards, facilitating the safe and convenient attachment of implements.

Vibration dampening and tractive power regulation, controlled via the lower linkage arms, ensure outstanding precision and comfort.



Muscle power put to good use.



Tractive power
Lift capacity

At the forefront
of versatility.



Forage harvesting specialist.

The CLAAS front linkage and front PTO shaft have been specially developed for the AXOS. Thanks to its compact design, the front linkage is integrated into the tractor and a high ground clearance of up to 49 centimetres is maintained.

With a maximum lift capacity of 2,800 kg, even extremely heavy front attachments can be used. The lift rams are dual-acting and can be operated in floating mode. This ensures that front-mounted devices follow ground contours evenly. The lift arms can be fully raised so that the AXOS retains unrestricted manoeuvrability.





Tailor-made for mowing.

The front linkage is located very close to the front axle. This ensures outstanding weight distribution and accurate control of front-mounted equipment. A lift range of 750 mm means that it is possible to drive over even very tall grass swaths without disturbing them.

The position of the front PTO shaft has been specifically chosen for use with front mowers. The drive shaft angle between tractor and mower is ideally suited to full power transfer. The mower is connected progressively and electrohydraulically via a switch in the side console on the right. A simple tap of the finger is all it takes.

Benefits of the integrated front linkage:

- High ground clearance and long lift range for driving over and maintaining grass and straw swaths without disturbing or damaging the sward
- Compact design for a short overall length
- Perfect transfer of force to the tractor
- Optimal guidance of front-mounted implements through close position of coupling points to the front axle
- The position of the front PTO shaft is ideal for working in combination with front mowers



Compact design for reduced overall length.

Front linkage
Front PTO shaft

Customisable ex factory.





A wide range of equipment

A machine tailored to your requirements.



AXOS made to measure.

To ensure that every farming requirement can be met, CLAAS has developed three versions of the elegant AXOS. Each model is based on one of the transmission variants. A wide range of additional equipment options are also available to enable you to create an AXOS tailored to your every need.

AXOS C – basic model with mechanical operation.

- Transmission: 10 F/10 R, 20 F/20 R fully mechanical
- Creep gear (optional)
- Mechanical linkage operation
- Up to three PTO shaft speeds
- Mechanical PTO shaft operation
- Low-roof cab with roof hatch or glass sunroof (optional), or high-roof cab with roof hatch or glass sunroof (optional)
- Air-suspended seat (optional)
- Extending mirrors (optional)





AXOS C



AXOS CX

AXOS CL – front loader specialist with REVERSHIFT.

- 10 F/10 R transmission with REVERSHIFT
- Creep gear (optional)
- Mechanical linkage operation
- Up to three PTO shaft speeds
- Hydraulically supported PTO shaft operation
- Low-roof cab with roof hatch or glass sunroof (optional) or high-roof cab with roof hatch or glass sunroof (optional)
- Adjustable steering column with automatic turn indicator cancellation (optional)
- Air-suspended seat (optional)
- Extending mirrors (optional)

AXOS CX – premium model with a wide range of applications.

- Transmission: 20 F/20 R with REVERSHIFT and TWINSHIFT or 30 F/30 R including creep gear
- TCE 9 electronic linkage operation (optional)
- Up to three PTO shaft speeds
- Hydraulically supported PTO shaft operation
- Low-roof or high-roof cab with roof hatch or glass sunroof
- Adjustable steering column with automatic turn indicator cancellation
- Air-suspended seat
- Extending mirrors

Available as retrofit set: the modern CLAAS steering systems CAM PILOT and GPS PILOT optimise the efficiency of your AXOS.



AXOS C
AXOS CL
AXOS CX



A choice of cab.

Three versions of the AXOS are available: two versions with cab (high- or low-roof), and one version without cab (with roll bar; platform version).

AXOS with high-roof cab.

With an overall height from 2.61 metres (with 16.9 R 30 tyres), the high-roof cab provides plenty of space. Enjoy the full comfort of CLAAS throughout those long days in the field. The wide-opening roof hatch or glass sunroof provides for additional ventilation.

AXOS with low-roof cab.

With the low-roof cab, the AXOS (with 16.9 R 30 tyres) boasts an overall height of just 2.46 metres, delivering all the benefits of a high-comfort tractor even when deployed in low-ceiling buildings. Like the high-roof version, the low-roof cab features a flat cab floor and roof hatch / glass sunroof.

AXOS without cab.

With an overall height of 1.95 metres (with roll bar retracted; with 16.9 R 30 tyres), the AXOS (platform version; without cab) is in its element in greenhouses or very low poultry barns. The roll bar can be retracted quickly and conveniently. This version, too, features a flat cab floor and the option of choosing between any of the transmission variants.

Each cab version can be fitted with a glass sunroof to add safety and convenience to front loader operations at full lift height.



All good things come in threes.



A choice of cab variants brings tangible benefits:

- Choose a cab that best meets your requirements and is most suited to your farm buildings.
- Maintain a perfect view of the front loader working area through the glass sunroof.
- Benefit from the full comfort of CLAAS AXOS in all three cab variants.



Cab variants



Open to any linkage.

The AXOS is extremely versatile – the integrated front linkage and the huge variety of coupling options at the rear make this abundantly clear. The AXOS can be linked up with just about any implement desired. You can also continue to use equipment already on the farm without any problems.

The AXOS offers a self-locking stabiliser (optional) in place of the standard lower linkage fixture for improved safety in the field and on the road.

Category 3/2 lower linkage coupling hooks are optionally available for each of the larger models (AXOS 330 and 340).

A variety of spool valves.

In terms of spool valves, CLAAS offers a choice of six equipment variants. Both the operation (via single lever or four-way control lever) and functions of the spool valves are variable. Whether single or dual-acting, or flow-regulated – the choice is yours.

Beneficial diversity:

- High standard of versatility, thanks to a wide range of linkage options
- Integrated front hydraulic system and front PTO shaft
- Wide choice of spool valves
- Automatic lower linkage fixture
- CAT 3/2 for AXOS 330 and 340



The AXOS –
a multitude of hitching options.



Hitching systems



A true friend and partner.

From day one, members of the CLAAS family benefit from the wide-ranging experience and expertise of the CLAAS group. The AXOS is no exception – the use of tried-and-tested components of CLAAS forage harvesting machines in tractor manufacturing ensures a high standard of reliability.

Easy to clean.

Tractors like the AXOS that are used on a daily basis must be easy to maintain and look after in all conditions. The flat cab floor and all the panelling are manufactured from dirt-resistant material and can be cleaned effortlessly.

Ready in a flash.

All daily maintenance tasks can be performed in next to no time in just a few simple steps, helping you to avoid unnecessary downtime:

- The one-piece bonnet provides quick and convenient access to all servicing and maintenance points.
- The cab air filter and engine air filter remain in easy reach, and can thus be cleaned quickly at any time.
- The radiator assembly can be folded upwards and locked into an open position with ease to provide unrestricted access to all radiator elements.
- The engine oil can be checked and topped up as required with the bonnet closed.
- All servicing points are easily accessible, even when a front loader is attached.



When you're on the go all day,
there's no time to waste.



Maintenance

Good partners never leave you in the lurch, no matter what time of day it is.





FIRST CLAAS SERVICE® around the clock.

Our years of experience and enormous knowledge base have familiarised us like no other with the working methods and individual requirements of farming businesses. We therefore understand exactly what our customers require and how we can best service their needs.

FIRST CLAAS SERVICE® has therefore come to represent absolute reliability and professionalism: in other words, we are there right away, whenever and wherever you need us. This applies to your AXOS just as it does to all other CLAAS machines.

Rest assured.

We are dedicated to supplying the ORIGINAL CLAAS spare parts you require whenever you need them. Our service is extremely well organised and proven over many years around the globe. We endeavour to do our utmost to minimise potential downtime, because we know as well as you do that time is money.

Dedicated teams.

Our highly trained service teams thoroughly enjoy their work and understand the issues perfectly, since expert knowledge and commitment are essential to successful teamwork. You will therefore always remain the kind of customer we're glad to have – completely satisfied.

AXOS: giving you its all.

An inviting workplace.

- Roof hatch or glass sunroof
- Simple and ergonomic operation
- Air-suspended seat
- Flat cab floor
- Large glass windows, clear view to the front and rear
- Hinged front windscreen (optional)
- Forward-opening doors (180°) can be locked into position

Always ready for action: your AXOS tractor.

- Minimal overall height with low-roof cab: 2.46 metres
- Mechanical transmission or REVERSHIFT with TWINSHIFT and optional creep gear
- Engines from 74 to 100 hp with turbocharger and internal exhaust gas recirculation
- Up to three PTO speeds: 540 / 540 ECO / 1,000 rpm
- Integrated front linkage
- Rear linkage with optional electronic draft control, vibration dampening and fingertip control on the rear mudguards
- Long wheelbase
- Short overall length and tight turning circle
- FIRST CLAAS SERVICE®

Unique: your specification.

- Three models: C, CL and CX
- Three cab variants
- Five transmission versions
- Wide variety of hitching devices
- Six different spool valve combinations

AXOS

		340	330	320	310
Engine					
Manufacturer		Perkins	Perkins	Perkins	Perkins
Number of cylinders/intake		4/TI	4/TI	4/T	4/T
Cubic capacity	cm ³	4,400	4,400	4,400	4,400
Bore/stroke	mm	105/127	105/127	105/127	105/127
Output at rated speed (ISO TR 14396 ¹ , 97/68/EC ²)	kW/hp	75/102	68/92	64/87	55/75
Output at nominal engine speed (ECE R 24)	kW/hp	74/100	66/90	63/86	54/74
Nominal engine speed	rpm	2,200	2,300	2,300	2,300
Engine speed at max. torque	rpm	1,400	1,400	1,200	1,200
Max. torque (ISO TR 14396 ¹ , 97/68/EC ²)	Nm	410	398	373	307
Max. torque (ECE R 24)	Nm	405	393	369	305
Torque rise	%	26	43	43	35
Visco fan		●	●	●	●
Max. fuel capacity	l	145	145	145	145
Oil-change interval	h	500	500	500	500
Transmission					
Manufacturer		CLAAS	CLAAS	CLAAS	CLAAS
Top speed	km/h	40/30	40/30	40/30	40/30
CX version					
REVERSHIFT – electrohydraulic reversing function		●	●	●	●
Mechanical gears		5	5	5	5
TWINSHIFT powershift transmission with 2 steps per ratio		●	●	●	●
Creep gears		○	○	○	○
Min. speed of creep gears at 2,200 rpm	km/h	0.44	0.44	0.44	0.44
Max. ratios (F/R)		30/30	30/30	30/30	30/30
CL version					
REVERSHIFT – electrohydraulic reversing function		●	●	●	●
Mechanical gears		5	5	5	5
Creep gears		○	○	○	○
Min. speed of creep gears at 2,200 rpm	km/h	0.54	0.54	0.54	0.54
Max. ratios (F/R)		15/15	15/15	15/15	15/15
C version					
Synchronised reversing gear					
Mechanical gears		5	5	5	5
Creep gears		○	○	○	○
Min. speed of creep gears at 2,200 rpm	km/h	0.54	0.54	0.54	0.54
Max. ratios (F/R)		15/15	15/15	15/15	15/15
Synchronised reversing gear with mechanical reduction					
Mechanical gears		5	5	5	5
Creep gears		○	○	○	○
Min. speed of creep gears at 2,200 rpm	km/h	0.44	0.44	0.44	0.44
Max. ratios (F/R)		30/30	30/30	30/30	30/30
PTO					
Clutch type depending on option				Mechanically/hydraulically supported	
540/1000		●	●	●	●
540/540 ECO		○	○	○	○
540/540E/1000		○	○	○	○
Changeable PTO shaft stub		●	●	●	●
Number of splines		6	6	6	6
Front PTO shaft 1,000 rpm		●	●	●	●
Road safety					
Braking system (multiple discs in oil bath and all-wheel auto activation)		●	●	●	●
Air brake system		○	○	○	○
Hydraulic trailer braking system		●	●	●	●

● Standard ○ Optional ■ Available – Not available ¹ Compliant with ECE R 120 (approx.)

² Performance data fit criteria for admissibility. Performance as per 97/68/EC is identical to 2000/25/EC.

AXOS

		340	330	320	310
All-wheel-drive front axle					
Electrohydraulic operation		●	●	●	●
Self-locking differential front/rear (self-locking multidisc clutch at front / dog clutch at rear)		●	●	●	●
Max. steering angle	degrees	55	55	55	55
Castor angle	degrees	6	6	6	6
Compensation angle	degrees	10	10	10	10
Turning radius	m	4.4	4.3	4.3	4.3
Track	mm	1,885	1,755	1,755	1,755
with tyres		13.6 R 24	11.2 R 24	11.2 R 24	11.2 R 24
Hydraulic system					
Hydraulic oil flow for linkage and spool valves	l/min	60	60	60	60
Max. operating pressure	Bar	180	180	180	180
Number of spool valves (min./max.)		2/3	2/3	2/3	2/3
4-way control lever		○	○	○	○
Flow regulation		Depending on equipment package			
Control units with lock-up valve		Depending on equipment package			
Rear lifting arms					
Max. lift capacity at ball ends (depending on equipment)	kg	5,100	4,200	4,200	3,300
Continuous lift capacity at 610 mm (depending on equipment)	kg	3,800	2,900	2,900	2,300
TRACTO CONTROL ELECTRONIC (TCE 9)		Optional for CX version only			
External operation for rear linkage		●	●	●	●
Lower and upper linkage with category 2 ball ends		–	●	●	●
Lower and upper linkage with category 2 coupling hooks		●	○	○	○
Lower and upper linkage with category 3/2 coupling hooks		○	○	–	–
Front lift linkage					
Front lift linkage		○	○	○	○
Max. lift capacity at ball ends	kg	2,800	2,800	2,800	2,800
Cab					
Low-profile roof		●	●	●	●
Platform		○	○	○	○
High-profile roof		○	○	○	○
Driver's seat, mechanically suspended		●	●	●	●
Driver's seat, air-suspended		○	○	○	○
Steering column, height and angle adjustable		Depending on equipment package			
Heating		●	●	●	●
Air conditioning		○	○	○	○
Opening rear window		●	●	●	●
Opening front screen		○	○	○	○
Stereo radio with 2 loudspeakers		○	○	○	○
Rear window wipers		○	○	○	○
Max. number of work lights		4 front / 4 rear			
Weight (standard tyres, with oil and fuel, without driver)					
Rear wheels		16.9 R 38	16.9 R 34	16.9 R 34	16.9 R 30
Front wheels		13.6 R 28	13.6 R 24	13.6 R 24	11.2 R 24
Weight without ballast	kg	4,200	3,730	3,730	3,650
Max. ballast weights ex factory	kg	4,922	4,352	4,152	3,972
Weight distribution with ballast (rear/front)	%	45/55	49/51	53/47	54/46
Permissible total weight	kg	8,500	7,500	7,500	7,500

● Standard ○ Optional ■ Available – Not available

CLAAS continually develops its products to meet customer requirements. This means that all products are subject to change without notice. All descriptions and specifications in this brochure should be considered approximate and may include optional equipment that is not part of the standard specifications. This brochure is designed for worldwide use. Please refer to your nearest CLAAS dealer and their price list for local specification details. Some protective panels may have been removed for photographic purposes in order to present the function clearly. To avoid any risk of danger, never remove these protective panels yourself. In this respect, please refer to the relevant instructions in the operator's manual.

Specifications

AXOS

		340	330	320	310
Dimensions (standard tyres)					
Rear wheels		16.9 R 38	16.9 R 34	16.9 R 34	16.9 R 30
Front wheels		13.6 R 28	13.6 R 24	13.6 R 24	11.2 R 24
Height with high-roof cab (a)	mm	2,710	2,660	2,660	2,610
Height with low-roof cab (b)	mm	2,561	2,511	2,511	2,461
Height with platform (roll bar extended/retracted) (b)	mm	2,706/2,050	2,656/2,000	2,656/2,000	2,606/1,950
Clearance between rear wheel centre point and roof (high-roof) (a)	mm	1,910	1,910	1,910	1,910
Clearance between rear wheel centre point and roof (low-roof) (a)	mm	1,761	1,761	1,761	1,761
Length					
Wheelbase (c)	mm	2,489	2,489	2,489	2,489
Overall length (without additional front weights) (d)	mm	4,181	4,181	4,181	4,181
Ground clearance					
Front axle (e)	mm	490	441	441	399
Rear axle (without swinging drawbar) (f)	mm	515	465	465	420

Tyres

Rear tyres	Front tyres				
16.9 R 30 (420/85 R 30)	11.2 R 24 (280/85 R 24)	–	◻	◻	◻
16.9 R 30 (420/85 R 30)	320/70 R 24	–	◻	◻	◻
480/70 R 30	11.2 R 24 (280/85 R 24)	–	◻	◻	◻
480/70 R 30	320/70 R 24	–	◻	◻	◻
540/65 R 30	11.2 R 24 (280/85 R 24)	–	◻	◻	◻
540/65 R 30	320/70 R 24	–	◻	◻	◻
16.9 R 34 (420/85 R 34)	13.6 R 24 (340/85 R 24)	–	◻	◻	◻
16.9 R 34 (420/85 R 34)	14.9 R 24 (380/85 R 24)	◻	–	–	–
480/70 R 34	380/70 R 24	–	◻	◻	◻
480/70 R 34	420/70 R 24	◻	–	–	–
540/65 R 34	440/65 R 24	–	◻	◻	◻
540/65 R 34	480/65 R 24	◻	–	–	–
16.9 R 34 (440/80 R 34)*	13.6 R 24 (360/80 R 24)*	–	◻	◻	◻
16.9 R 34 (440/80 R 34)*	14.9 R 24 (400/80 R 24)*	◻	–	–	–
12.4 R 36 (320/85 R 36)	11.2 R 24 (280/85 R 24)	–	◻	◻	◻
12.4 R 36 (320/85 R 36)	320/70 R 24	–	◻	◻	◻
13.6 R 36 (340/85 R 36)	12.4 R 24 (320/85 R 24)	–	◻	◻	◻
18.4 R 30 (460/85 R 30)	12.4 R 24 (320/85 R 24)	–	◻	◻	◻
18.4 R 34 (460/85 R 34)	14.9 R 24 (380/85 R 24)	–	◻	◻	◻
18.4 R 34 (460/85 R 34)	13.6 R 28 (340/85 R 28)	◻	–	–	–
520/70 R 34	420/70 R 24	–	◻	◻	◻
520/70 R 34	380/70 R 28	◻	–	–	–
600/65 R 34	480/65 R 24	–	◻	◻	◻
600/65 R 34	440/65 R 28	◻	–	–	–
13.6 R 38 (340/85 R 38)	13.6 R 24 (340/85 R 24)	◻	◻	◻	◻
16.9 R 38 (420/85 R 38)	13.6 R 28 (340/85 R 28)	◻	–	–	–
540/65 R 38	440/65 R 28	◻	–	–	–

● Standard ○ Optional ◻ Available – Not available * Tyres with industrial tread

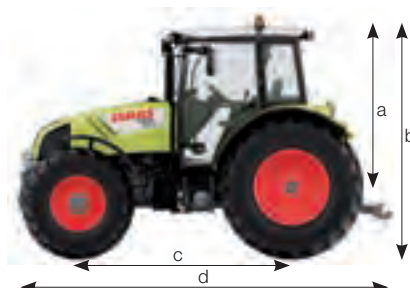



CLAAS UK
Saxham
Bury St. Edmunds
Suffolk
IP28 6QZ
Tel 01284 763100
claas.co.uk
info-uk@claas.com
341012130110 KK Be 0910