

6030 Series Tractor

62.5 to 114 kW (85 to 155 hp) (97/68 EC)



Table of Contents

Introduction 2 – 3

Cab/Comfort 4 – 5

Engine 6 – 7

Transmissions 8 – 9

Livestock Operations 10 – 11

Arable Operations 12

Service/Support 14

Specifications 15

Dealer Commitment 16



- At A Glance –**
- Greater selection
 - Two models especially for arable operations
 - Spacious, comfortable cab
 - Efficient engine

- Models***
- | | |
|------------------------|------------------------|
| 6130 – 62.5 kW (85 hp) | 6534 – 92 kW (125 hp) |
| 6230 – 70 kW (95 hp) | 6630 – 99 kW (135 hp) |
| 6330 – 77 kW (105 hp) | 6830 – 107 kW (145 hp) |
| 6430 – 88 kW (120 hp) | 6930 – 114 kW (155 hp) |

* All models to 97/68 EC

Broaden your horizons

Want to expand your operation's horizons? Look no further than our powerful, versatile and efficient line of 6030 Series tractors.

The 6030 Series offers high horsepower combined with John Deere's proven reliability. The 107 kW (145 hp) 6830 and 114 kW (155 hp) 6930 deliver extra muscle to tackle the kind of tough jobs you face daily in arable applications.

Want even more efficiency? Get our new 6534 model. We have fitted a lighter yet more powerful 4 cylinder engine into our incredibly stable 6-cylinder full frame chassis so that you can carry larger loads, pull more easily on inclines and roads and still reduce your fuel consumption. In combination with the large fuel tank and big load spreading tyres you have a clear advantage in the fields and on the road providing more full-day productivity.



Broader Visibility

The expansive front window and optional glass roof hatch provide a wide-open view to your surroundings. Visibility to the rear drawbar is also unobstructed for quick and easy hook-ups.



Broader Comfort

This cab cradles you in comfort as you power through your tasks. Plus, an electrical left-hand reverse makes loader work fast, easy and smooth.



Broader Line-up

The 6830 and 6930's high horsepower and proven reliability make them ideal for livestock and arable operations.



Broader Productivity

John Deere Triple Link Suspension provides higher operator comfort, reduces operator fatigue and increases productivity in the field and on the road.

Exceptional visibility

Ease into the spacious cab from either side and surround yourself in all-day comfort and convenience.

Enjoy exceptional visibility in all directions as well as controls that are logically placed, easy to use and within close reach. It's a comfortable environment that makes your working day more enjoyable and productive.

But it doesn't stop there. Left and right hand doors, high capacity ventilation and a spacious interior ensure you get the highest possible level of functional luxury in this tractor class.



Optional roof hatch with glass makes it easy to see loads that are normally out of sight when working in tight, low buildings.



Optional tiltable front windshield can be adjusted to improve cab air flow.

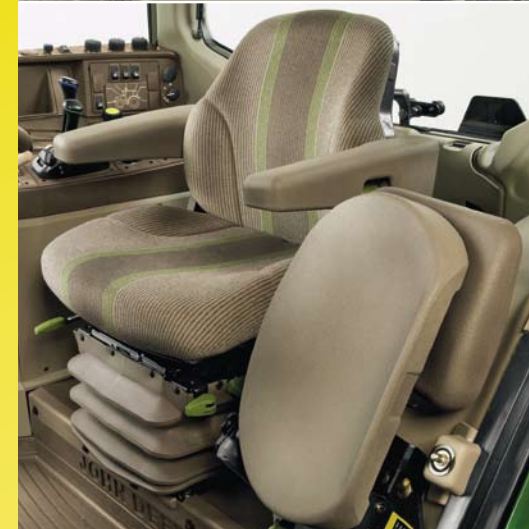

Optional instruction seat can be folded out of the way when not in use.

At A Glance –

- Exceptional visibility
- Easy to use controls
- Spacious, comfortable cab



1 Instantly change direction with the electric left-hand reverser while you keep your right hand on the controls. Loader work and complex headland turns are smooth and easy.

2 Our tilt/telescopic steering column adjusts to fit almost any operator perfectly.

3 The easy to read instrument cluster conveniently moves with the steering column.

4 The heating and cooling system is strategically placed within easy reach on the right-hand console. The result is an unobstructed view out of the front windshield.

Optional FieldOffice provides removable storage for pens, notes, manuals and documents.



Reliable power

When you're ready to start working, our field-proven 4.5 L and 6.8 L PowerTech engines are ready. Our 2-valve High Pressure CommonRail (HPCR) engines deliver rapid response and efficiency.

High torque and extra power comes from the dual-stage temperature cooling system and charge air cooler. This combination keeps fuel consumption and maintenance costs low.

It's a total package of John Deere innovation and reliability that can help you keep your operating costs low.



At A Glance –

- 4.5 L and 6.8 L PowerTech engines
- HPCR engine delivers excellent performance
- Dual-stage charge air cooler and dual temperature cooling system improve fuel economy

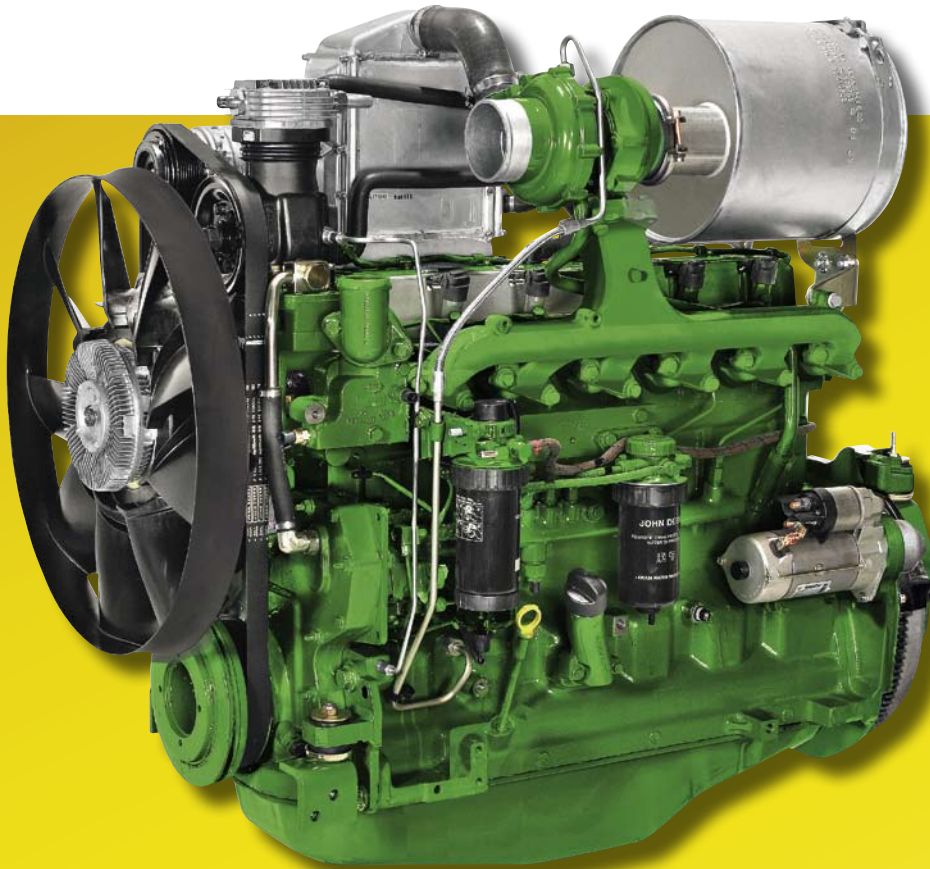

Tillage work is no challenge for the robust power of the 6830 or 6930.

- 1 Power core air filter** with built-in pre cleaner removes more than 93% of foreign material before it reaches the filter element.
- 2 Dual-temperature cooling system** helps our engines run at peak performance and efficiency.
- 3 The 2V-CR (two valves per cylinder and CommonRail fuel delivery)** delivers excellent torque reserve – up to 33% – giving you plenty of lugging ability.
- 4 Extra power when you need it** – up to 5%, plus 20% constant power. You'll always have the power you need.
- 5 Electronically controlled HPCR fuel injection** delivers excellent fuel efficiency.
- 6 Dual-stage charge air cooler** with twin coolant pass system provides accurate temperature control for improved performance and outstanding fuel efficiency.

John Deere Power Tech Engine (Up to 33% engine torque at 6930)

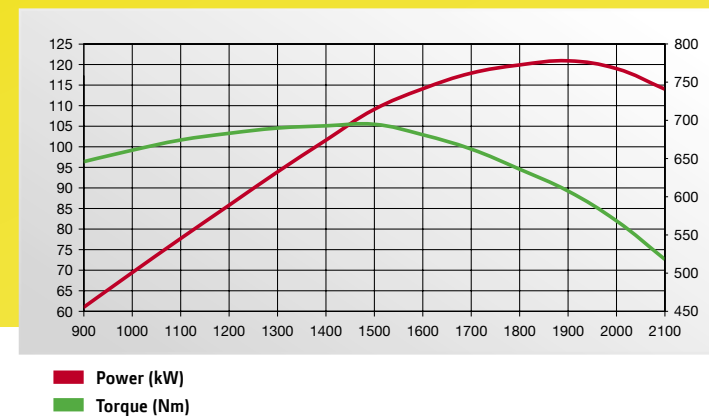

Up to a 33% engine torque rise helps you power through tough conditions.

PowerQuad Plus Transmission

Optional 16/16 PowerQuad Plus Transmission offers four power shiftable speeds in each of four fully synchronised ranges. Shift between ranges with the single-lever range shuttle and clutch (not for 6830/6930).

Optional 24/24 PowerQuad Plus Transmission with up to 40 km/h top speed is available on all models. You get more gears in the main working range and more flexibility (6830 and 6930 come with 20/20 PowerQuad Plus transmission in base).

Quickly and easily change direction with the electric left hand reverser – standard equipment with the PowerReverser 16/16 and PowerQuad transmissions.



At A Glance –

- 3 main transmission choices with multiple options
- Comfortable, easy to use controls
- Left hand reverser at PowerReverser and PowerQuad Plus transmission



Harness the power

You can choose from one of three different transmissions to harness the power of your 6030 Series tractor.

- **6030 Series Tractors:** SyncroPlus transmission (30 k), PowerReverser (30 k and 40 k), PowerQuad Plus transmission (30 k and 40 k) (6830/6930 comes with PowerQuad Plus 40 k).
- **Open Station 6030 Series Tractors:** Syncro Plus (30 k), PowerReverser (30 k and 40 k), PowerQuad transmission (30 k and 40 k).

SyncroPlus 12/4 transmission has 12 forward and 4 reverse speeds. Ranges and speeds are fully synchronised and allow you to shift on-the-go. First and reverse gears are positioned in-line for easy forward/reverse shifting.

Optional PowerReverser 16/16 has 16 forward and 16 reverse speeds, plus a left hand reverser for clutchless direction changes that speed up loader work.

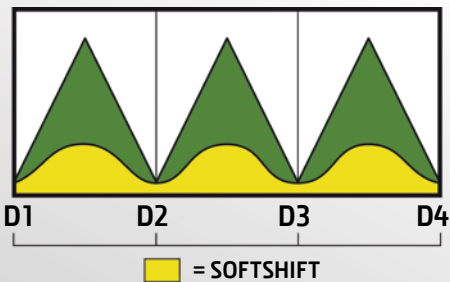

Our exclusive SoftShift technology provides you with smooth gear changes, even under load. The engine and transmission communicate electronically to provide smooth, integrated shifts for enhanced operator comfort. SoftShift comes standard on both PowerQuad Plus transmissions.

24/24 PowerQuad Plus Transmission with single lever shifting



New versatility for livestock producers

A dependable tractor is a must in the livestock business and our rugged and versatile tractors are up to the task.

A John Deere loader moves large bales, cleans pens and loads feed with ease. Use the integrated left hand reverser to quickly change direction regardless of the loader application you are performing.

But that's not all. These tractors are also an ideal choice for towing, baling, spreading manure and all of the other tasks around your operation.

The John Deere loader works perfectly in combination with the Tripple Link Suspension (TLS). You go faster moving bales out from the field without losing ride comfort.



At A Glance –

- Integrated left hand reverser and great visibility make loader work quick and easy
- Full-frame, long-life design ensures years of dependable service



The optional joystick provides convenient operation and unrestricted movement in the cab. In combination with our PowerQuad Plus transmissions, you'll find optional speed buttons on top of the handle for easy up or down shifts.

An auxiliary hydraulic function switch on the front of the joystick makes it easy to operate attachments such as a grapple or silage cutter.



Views out of the front window are unobstructed so you can operate your loader with confidence – especially in confined areas, barns or other buildings.



Our tractor's full-length frame manages the load stresses, even when the bucket is filled unevenly. This reduces the twisting forces on the engine and drive train components during operation.

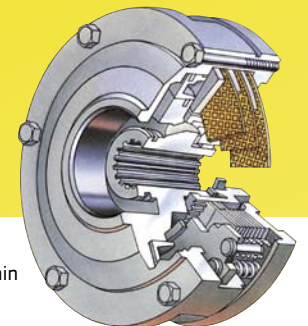

The reliable, self adjusting PermaClutch 2 main drive clutch ensures long lasting performance and smooth modulation engagements.

When it comes to making quality hay we make it simple. Our tractors, balers, sprayers and monitors are all John Deere built and work seamlessly together. Connections are trouble-free. Ask your local dealer about a complete John Deere hay-making solution that fits your operation.





John Deere GreenStar Lightbar with StarFire 300 receiver

We offer a number of guidance solutions for your tractor. Our AutoTrac Universal 200 system is a single automatic guidance solution that fits the entire fleet of different vehicles. Or you choose the easy to install Lightbar system. The John Deere GreenStar Lightbar system teamed with the StarFire 300 receiver can be set up quickly for immediate use on all machines. Both are compatible with 6030 Series tractors and also fit many other John Deere and non John Deere tractors. Your local dealer can help you choose the guidance system that best fits your operation.

Stay one step ahead

Till, disc or seed your field or bring in your last load of grain. Our 6030 Series tractors help you broaden the horizons of your arable operation and keep you one step ahead.

The 107 kW (145 hp) 6830 and 114 kW (155 hp) 6930 are made to work on large livestock or arable operations. Put more power to the ground with the optional Triple Link Suspension (TLS) and enjoy a smooth ride. These tractors also come equipped with innovative hitches that use linear rockshaft control and hitch dampening to smooth out your ride during transport.

Optional electronic hitch sensing* and a conveniently located remote on the fender, make implement connecting quick and easy.

The in-cab PTO speed change system, makes it easy to move between implements.

*Standard in UK and Ireland

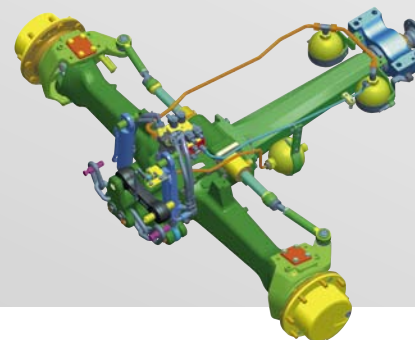

Triple Link Suspension (TLS) is a true suspension system, so front wheels follow the ground contours. It absorbs bumps hydraulically instead of passing them to the frame and cab. Providing the operator with the ultimate comfort, you maintain better traction and increase pulling power.



As versatile as you need. The three-in-one hitch rail lets you use a variety of connections, from ball, wagon to piton.

*A pick-up hitch is also available. These tractors can accommodate most any system around.

You have a clear, unobstructed view to the drawbar from the cab.

At A Glance –

- Two high horsepower models
- Available with Triple Link Suspension
- Excellent visibility to the drawbar
- In cab PTO speed change makes implement changes easy



Maintenance made simple

Servicing your 6030 Series tractor is easy. The single-piece tilt hood features two positions for easy engine, radiator and component access. A strong gas strut holds the hood securely in place at a 45 degree angle while you work. Or, if needed, you can override the strut and position the hood vertically for maximum clearance.

Easy access to filters and service points help ensure that regular maintenance tasks are accomplished without difficulty. Plus, the engine oil change interval is 500 hours. That helps keep your cost of ownership low.

In addition, other vital components such as brakes and clutches require little or no maintenance. They're built to provide excellent service throughout the normal life of the tractor.

Easy to service. Multiple service-free components and easy daily service points minimise the need for more extensive care.

At A Glance –

- Single-piece tilt hood for easy access to service points
- 500 hour engine oil change interval
- Multiple service-free components reduce cost of ownership

Specifications

Engine Performance	6130	6230	6330	6430	6534	6630	6830	6930
Stage III certified acc. 97/68/EC								
Rated power (97/68 EC), kW (hp)	63 (85)	70 (95)	77 (105)	88 (120)	92 (125)	99 (135)	107(145)	114 (155)
Maximum Power (97/68/EC), kW (hp)	66 (89)	74 (101)	81 (110)	93 (126)	97 (131)	104 (142)	112(152)	120 (163)
Rated power (ECE-R24), kW (hp)	60 (82)	67 (91)	74 (100)	85 (115)	88 (120)	95 (130)	103 (140)	110 (150)
Maximum Power (ECE-R24), kW (hp)	64 (86)	70 (96)	78 (106)	89 (121)	93 (126)	100 (136)	108 (147)	116 (158)
Cylinders/Turbo/Charge Air Cooler/Displacement, ccm	4/T/X/4530	4/T/X/4530	4/T/X/4530	4/T/X/4530	4/T/X/4530	6/T/X/6780	6/T/X/6780	6/T/X/6780
Rated Speed, rpm	2300	2300	2300	2300	2300	2300	2100	2100
Max Power at engine speed, rpm	2100	2100	2100	2100	2100	2100	2100	2100
Engine Speed at max. Torque, rpm	1500	1500	1500	1500	1500	1500	1300	1300
Constant power range, rpm	500	500	500	500	500	500	450	450
Torque Reserve, %	33	33	33	33	33	33	33	33
Fuel injection system	Full authority electronic engine management							
Type of injection	2 Valve High Pressure CommonRail							
Cooling	Dual Temperature Cooling							
Fan	Temperature controlled viscous fan							
Air cleaner	PowerCore precleaning							
Clutch	Oil cooled, PermaClutch 2, 225 mm diameter discs							
Transmission								
SyncoPlus								
12/4; 2.5 – 30 km//h	•	•	•	•	•	•	–	–
PowerReverser	Electrical Left Hand PowerReverser with neutral position; F/R Ratio 1:1							
16/16; 1.9 – 30 km/h or 2.5 – 40 km/h	•	•	•	•	•	•	–	–
PowrQuad Plus	4 powershiftable gears; Electrical Left Hand PowerReverser with neutral position; F/R Ratio 1:1							
16/16; 2.5 – 30 km/h	•	•	•	•	•	•	–	–
16/16; 3.1 – 40 km/h	•	•	•	•	–	–	–	–
20/20; 2.5 – 40 km/h	–	–	–	–	–	–	•	•
24/24; 1.6 – 40 km/h	•	•	•	•	•	•	–	–
Additional 12/12 Creeper reduction 1:10	Option for PowerReverser and PowrQuad Transmission							
PTO – Rear								
PTO Clutch	Electro-hydraulically operated oil cooled multi-disc clutch							
540/540E/1000 Rear PTO at rated PTO speeds	2143/1684/2208	2143/1684/2208	2143/1684/2208	2143/1684/2208	2143/1684/2208	2143/1684/2208	1995/1743/1995	1995/1743/1995
Brakes								
Foot brake	Oil cooled discs, self equalizing, self adjusting							
Parking lock	Transmission parking position.							
4WD braking	Automatic 4WD engagement							
Axles								
2WD version	•	•	•	•	•	–	–	–
Engagement 4WD	Electro-hydraulically operated, oil cooled clutch							

Engine Performance	6130	6230	6330	6430	6534	6630	6830	6930
Engagement front differential lock	Automatic self locking under full load							
Engagement rear differential lock	Electro-hydraulically operated, oil-cooled multi-disc							
Caster angle/turning radius w/o brakes 4WD in mm	12°/4440	12°/4440	12°/4500	12°/4500	12°/5100	12°/5100	12°/5200	12°/5200
Hydraulic System and 3-point-hitch								
Type (base)	Load sensing with constant flow pump (PC = pressure compensated)							
Type (option)	–	–	–	–	–	–	Pressure and flow compensated (PFC)	
Pump capacity (l/min) / maximum pressure with PC	65 or 80 with 200 bar (PC)						80 with 200 bar (PC)	
Pump capacity (l/min) / maximum pressure with PFC	–	–	–	–	–	–	110 with 200 bar (PFC)	
Category	II opt. II/IIIN	II opt. II/IIIN	II opt. II/IIIN		II opt. II/IIIN	II opt. II/IIIN	II/IIIN	II/IIIN
Sensing type	Electronic lower link							
Sensing modes	Load & depth control, infinite mix, float							
Control modes	Height limiter, working depth, rate of drop, quick raise, quick pull-in; Hitch dampening							
Max. lift capacity base/optional, kN	37.4/49.8	43.4/49.8	43.4/49.8	49.8/57.2	49.8/57.2	49.8/64.6	66.6/75.2	66.6/75.2
Capacity								
Fuel Tank base/optional, l	165/185	165/185	165/185	165/185	207/250	207/250	250/325	250/325
Alternator/Battery, A/Ah	90/110 opt. 120/154	90/110 opt. 120/154	90/110 opt. 120/154	90/110 opt. 120/154	90/154 opt. 120/174	90/154 opt. 120/174	90/154 opt. 120/174	90/154 opt. 120/174
Hydraulic & Transmission oil/change interval in l/h	50/1500	50/1500	50/1500	50/1500	50/1500	50/1500	50/1500	50/1500
Engine Oil/change interval in l/h	16/500	16/500	16/500	16/500	16/500	19.5/500	19.5/500	19.5/500
Engine Coolant/change interval in l/h	24/3000	24/3000	24/3000	24/3000	24/3000	28/3000	28/3000	28/3000
Cab								
Specification	Tiltable cab; 310° all-round vision; climate control, telescoping and tiltable steering column/wheel; opt. FieldOffice							
Sound Reduction/Level, dB(A)	71	71	71	71	70	70	72	72
Display	Tilt with steering wheel	Tilt with steering wheel	Tilt with steering wheel	Tilt with steering wheel	Tilt with steering wheel	Tilt with steering wheel	Tilt with steering wheel	Tilt with steering wheel
Dimensions and Weights								
Wheelbase, mm	2400	2400	2400	2400	2650	2650	2650	2650
Width x Height x Length, mm	2275 x 2718 x 4289	2275 x 2718 x 4289	2316 x 2743 x 4289	2316 x 2743 x 4289	2316 x 2833 x 4728	2316 x 2833 x 4728	2382 x 2923 x 4758	2382 x 2923 x 4758
With tyre size	14.9R24 and 16.9R38	14.9R24 and 16.9R38	16.9R24 and 18.4R38	16.9R24 and 18.4R38	420/70R28 and 18.4R38	420/70R28 and 18.4R38	16.9R28 and 20.8R38	16.9R28 and 20.8R38
Minimum shipping weight, kg	4640	4640	4745	4745	5165	5165	5635	5635
Maximum Permissible Gross Weight at 40 km/h, kg	7600	7600	8200	8200	8500	9500	10000	10500

* Specifications and design subject to change without notice

World-class sales, service and support

When it comes to service and support after the sale, nothing matches the reliability of your John Deere dealer.

Whether it's a critical parts requirement for any of your equipment, regular tune-ups or emergency repair, your dealer stands ready to deliver a prompt, friendly service. It's all part of our long term commitment to your success.

No matter what your power requirements, our dealers have the products and services you need to run a successful operation.

At A Glance –

- A worldwide network of dealers ensure support wherever you need it
- 24-hour access to parts and online ordering
- Unmatched product knowledge



www.JohnDeere.co.uk
www.JohnDeereInternational.com
www.JohnDeere.co.za
www.Deere.com.au



JOHN DEERE CREDIT

"Take the credit for buying the best"

John Deere Credit – A range of finance options as powerful as our products. Contact your John Deere dealer for a comprehensive range of finance options to suit the specific needs of your business.
Not available in all countries please consult your local dealer.

This literature has been compiled for worldwide circulation. While general information, pictures and descriptions are provided, some illustrations and text may include finance, credit, insurance, product options and accessories NOT AVAILABLE in all regions. PLEASE CONTACT YOUR LOCAL DEALER FOR DETAILS. John Deere reserves the right to change specification and design of products described in this literature without notice.
"John Deere's green and yellow colour scheme, the leaping deer symbol and JOHN DEERE are trademarks of Deere & Company."



JOHN DEERE