

# LANDPOWER, TIER 3 ENGINES AND ELECTRONIC TRANSMISSION FOR IMPRESSIVE PERFORMANCE.

The new LandPower tractor has been redesigned with the adoption of the new F.P.T. Tier 3 engines and of an electronically-controlled transmission, making it ideal for all open-field applications as well as for high-speed road transport.

All models are powered with the new F.P.T. NEF 2V 6-cylinder turbo engines. Equipped with *air-to air intercooler*, the new engines meet the Tier 3 emission regulations and deliver up to 157 HP, providing exceptional torque and power levels.

The LandPower tractors have two different transmissions: the *Speed Six*, a completely mechanical transmission specially designed for the *Techno* and the electronically-controlled *Top-Tronic* transmission with *Declutch Control* and *Reverse Power Shuttle* for the *Comfort* and *Top-Tronic*.

The hydraulics feature five BOSCH auxiliary valves and the front axle can be optionally supplied with L.S.A hydraulic suspensions.

The cab provides a comfortable driving position with ergonomically-arranged controls. The air-conditioning, installed on the cab roof, ensures the driver a safe and healthy work environment.

The plunging line of the hood, in keeping with the Landini *Family Style*, and the large glass area of the cab provide total visibility enhancing manoeuvrability and driving comfort.



	LANDPOWER 125		LANDPOWER 135		LANDPOWER 145		LANDPOWER 165	
	TECHNO	COMFORT	TECHNO	COMFORT	TECHNO	COMFORT	TECHNO	COMFORT
<b>ENGINE</b>								
F.P.T. TURBO/INTERCOOLER AIR-AIR (TIER 3)			NEF 2V	NEF 2V	NEF 2V	NEF 2V	NEF 2V	NEF 2V
MAX. ENGINE POWER (ISO)	HP/KW		117/86	133/98	141/104	157/116		
MAX. TORQUE	LB. (NM)		380 (515)	435 (590)	461 (625)	509 (691)		
NR. OF CYLINDERS/DISPLACEMENT	CU. IN. (CM³)		6728/6	6728/6	6728/6	6728/6		
FUEL TANK CAPACITY	GAL. (LT)		68 (260)	68 (260)	68 (260)	68 (260)		
<b>CLUTCH</b>								
DOUBLE-PLATE DRY CLUTCH	14" (355 MM)		●	–	●	–	●	–
MECHANICALLY OPERATED			●	–	●	–	●	–
MULTI-DISK WET CLUTCH			–	●	–	●	–	●
DE-CLUTCH CONTROL: BUTTON-OPERATED CLUTCH			–	●	–	●	–	●
<b>TRANSMISSION</b>								
SPEED SIX + CREEPER + REV. SHUTTLE. 36FWD + 36REV			●	–	●	–	●	–
SYNCHRONISED MECHANICAL REVERSE POWER SHUTTLE			●	–	●	–	●	–
TOP-TRONIC + SPEED SIX + CREEPER 108AV+36RM			–	●	–	●	–	●
REVERSE POWER SHUTTLE: REVERSE POWER SHUTTLE UNDER LOAD			–	●	–	●	–	●
CRUISE CONTROL: AUTOMATIC ENGINE SPEED CONTROL			–	●	–	●	–	●
<b>P.T.O.</b>								
MECHANICAL ENGAGEMENT BY LEVER			●	–	●	–	●	–
CLUTCH OIL-IMMERSED MULTI-DISK PTO			–	●	–	●	–	●
ELECTROHYDRAULIC ENGAGEMENT			–	●	–	●	–	●
2 SPEEDS: 540/1000 RPM			●	●	●	●	●	●
NET PTO POWER (ISO)	HP/KW		100/73	114/83	120/88	135/99		
<b>4WD FRONT AXLE</b>								
RIGID TYPE			●	●	●	●	●	●
L.S.A. "LANDINI SUSPENDED AXLE" - AXLE WITH HYDRAULIC SUSPENSIONS			○	○	○	○	○	○
ELECTROHYDRAULIC 4WD ENGAGEMENT			●	●	●	●	●	●
MAX. STEERING ANGLE 55°			●	●	●	●	●	●
TWIN-LOCK ELECTROHYDRAULIC DIFF-LOCKS			●	●	●	●	●	●
TURNING RADIUS WITHOUT BRAKES	IN. (MM)		210 (5350)	210 (5350)	210 (5350)	210 (5350)		
<b>HYDRAULIC POWER LIFT</b>								
MECHANICALLY OPERATED			●	●	●	●	●	●
ELECTRONICALLY-OPERATED "LANDTRONIC"			●	●	●	●	●	●
FUNCTIONS: POSITION CONTROL, INTERMIX, FLOAT POSITION, SHOCK ABSORBER			Top Tronic	Top Tronic	Top Tronic	Top Tronic		
LIFTING CAPACITY WITH 2 AUXILIARY CYLINDERS Ø 90 (100*)	LB. (KG)		15400 (7000)	15400 (7000)	15400 (7000)	15400 (7000)		
HYDRAULIC FLOW @ REMOTE (MECHANICAL POWER LIFT)	GPM (L/MIN)		18 (67.7)	18 (67.7)	18 (67.7)	18 (67.7)		
TOTAL HYDR. FLOW (MECHANICAL POWER LIFT)	GPM (L/MIN)		28 (105.7)	28 (105.7)	28 (105.7)	28 (105.7)		
HYDRAULIC FLOW @ REMOTE (ELECTR. POWER LIFT)	GPM (L/MIN)		23 (87) Top Tronic	23 (87) Top Tronic	23 (87) Top Tronic	23 (87) Top Tronic		
TOTAL HYDR. FLOW (ELECTR. POWER LIFT)	GPM (L/MIN)		33 (125) Top Tronic	33 (125) Top Tronic	33 (125) Top Tronic	33 (125) Top Tronic		
AUXILIARY VALVES MAX. NR° STD/OPT			3/5	3/5	3/5	3/5		
STD AUXILIARY VALVES			5 Top Tronic	5 Top Tronic	5 Top Tronic	5 Top Tronic		
ELECTROHYDRAULIC DIVERTER FOR AUXILIARY VALVE			Top Tronic	Top Tronic	Top Tronic	Top Tronic		
<b>CAB AND DRIVING SEAT</b>								
AIR-CONDITIONING			●	●	●	●	●	●
MECHANICAL SEAT			●	●	●	●	●	●
PNEUMATIC SUSPENSION SEAT			○	○	○	○	○	○
PNEUMATIC SUSPENSION SEAT			Top Tronic	Top Tronic	Top Tronic	Top Tronic		
<b>DIMENSIONS AND WEIGHTS</b>								
STD REAR TYRES			480/70R38	520/70R38	520/70R38	600/65R38		
A HEIGHT OVER CAB	IN. (MM)		109 (2780)	109 (2780)	110 (2800)	110,5 (2810)		
B WHEELBASE	IN. (MM)		110 (2800)	110 (2800)	110 (2800)	110 (2800)		
C MAX. LENGTH (WITH BALLAST WEIGHTS)	IN. (MM)		202,5 (5145)	202,5 (5145)	214,5 (5450)	214,5 (5450)		
D GROUND CLEARANCE	IN. (MM)		20,5 (520)	20,5 (520)	21 (540)	21,5 (550)		
E MIN/MAX WIDTH	IN. (MM)		81/100 (2060/2560)	87/103 (2212/2612)	86/109 (2180/2784)	94/113 (2384/2884)		
TOTAL WEIGHT (WITHOUT BALLAST WEIGHTS)	LB. (KG)		12760 (5800)	12760 (5800)	13090 (5950)	13750 (6250)		

Key: ● standard ○ option – not available

NB: TOP-TRONIC and COMFORT are equal, unless otherwise specified in the table

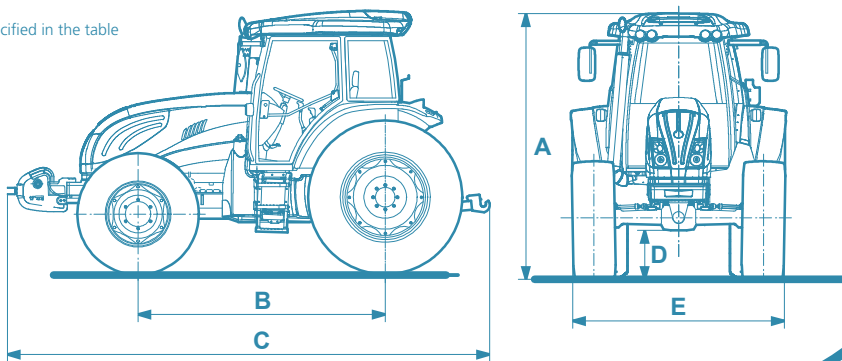

# Landpower

125 - 135 - 145 - 165  
TECHNO - COMFORT - TOP-TRONIC



LandPower®





**NEW F.P.T NEF 2V SERIES TIER 3 ENGINES WITH NEW TILTING HOOD.**

ALL LANDPOWER TRACTORS FEATURE 6-CYLINDER TURBO ENGINES WITH *AIR-TO-AIR INTERCOOLER* AND MECHANICAL INJECTION SYSTEM.

QUIET AND FUEL-EFFICIENT, THE NEF 2V SERIES ENGINES MEET THE TIER 3 EMISSIONS REGULATIONS AND PROVIDE CONSTANT POWER AND HIGH TORQUE BACKUP FOR A GREAT FLEXIBILITY OF USE.

THE TILTING HOOD PROVIDES EASY ACCESS TO THE ENGINE FOR ROUTINE SERVICE AND MAINTENANCE. > FIG. A

**LSA AXLE WITH HYDRAULIC SUSPENSIONS (LANDINI SUSPENDED AXLE).**

THE ELECTRONICALLY-CONTROLLED SUSPENDED AXLE ENSURES HIGH SPEEDS ON ROUGH GROUNDS AND IMPROVES TRACTION AND MANOEUVRABILITY FOR ENHANCED COMFORT, SAFETY AND PRODUCTIVITY, WHILE KEEPING GROUND CLEARANCE UNALTERED. > FIG. B

**FRONT POWER LIFT FOR ADDED VERSATILITY (OPTIONAL).**

THE FRONT POWER LIFT WITH CAT. 2 HITCH PROVIDES THE MAIN RAISING/LOWERING AND FLOATG FUNCTIONS AND ENSURES A MAXIMUM LIFT CAPACITY OF 7700 LB. (3500 KG). THE FRONT POWER LIFT HAS BEEN SPECIALLY DESIGNED TO ENHANCE THE VERSATILITY OF THE LANDPOWER TRACTOR RANGE. > FIG. B

**TOP-TRONIC TRANSMISSION (108FWD + 36REV) WITH DE-CLUTCH CONTROL AND REVERSE POWER SHUTTLE**

THE *TOP-TRONIC* TRANSMISSION TRIPLES UNDER LOAD THE 36 SPEEDS OF THE BASIC TRANSMISSION OFFERING A TOTAL CHOICE OF 108 FORWARD 36 REVERSE GEARS. THE *TOP-TRONIC* IS ACTIVATED WITH THE GREEN BUTTONS INTEGRATED IN THE GEAR LEVER. THE *DE-CLUTCH CONTROL* (ORANGE BUTTON ON THE GEAR LEVER) (FIG. C) AND THE REVERSE POWER SHUTTLE (LEVER UNDER THE STEERING WHEEL) (FIG. D) ENABLE CLUTCH-LESS ENGAGEMENT AND REVERSAL OF ALL GEARS.

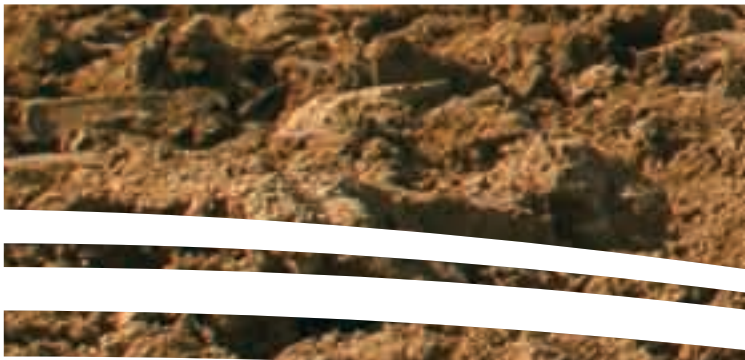
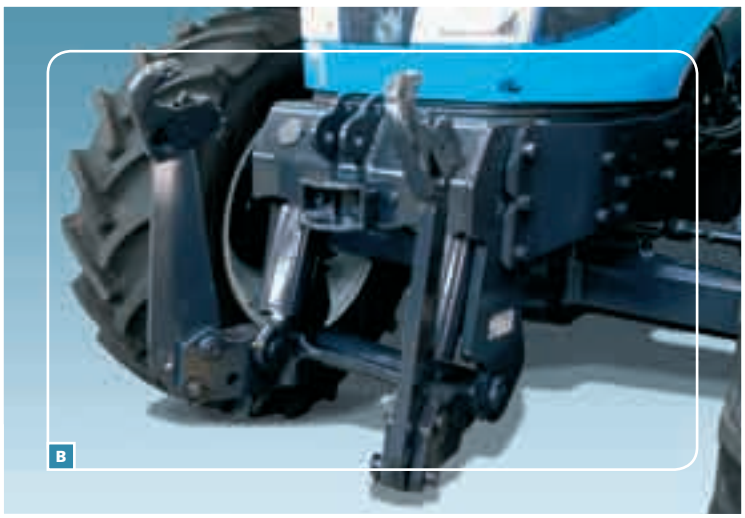



**LANDPOWER, A WORLD OF TECHN**



**BUSINESS CLASS  
FITTED AIR-CONDITIONING**

THE CAB MOUNTED AIR-CONDITIONING PLATFORM FEATURES A CONVENIENTLY ACCESSIBLE CONTROL PANEL. THE LATEST ERGONOMICS, HEATING, VENTILATION AND AIR-CONDITIONING SYSTEMS. THE CAB ROOF WITH COOLING SYSTEMS. IN TERMS OF SAFETY, THE CAB ROOF ARE ALSO EQUIPPED WITH SPECIALLY USEFUL WORKING LIGHTS AND EIGHT LIGHTS

**NOLOGY AT YOUR SERVICE.**

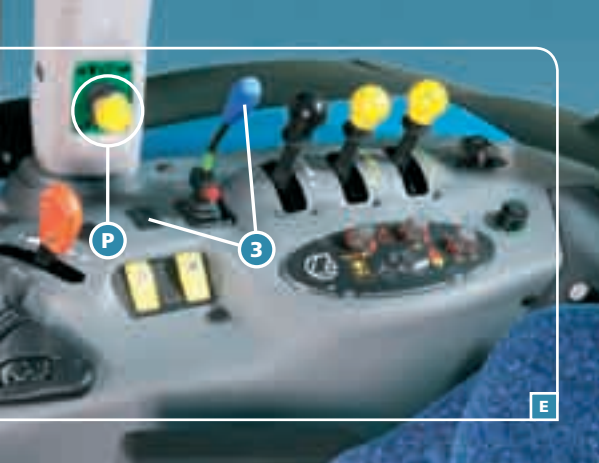

### NEW ELECTRONIC LANDTRONIC POWER LIFT WITH SHOCK ABSORBER.

THE NEW ELECTRONICALLY-CONTROLLED LANDTRONIC POWER LIFT WITH RATIONALLY-ARRANGED CONTROLS LOCATED IN ERGONOMIC POSITION ON THE CONSOLE (FIG. H) INCORPORATES ALL MAIN FUNCTIONS AND REGULATIONS (FIG. G) OFFERING MAXIMUM COMFORT AND FINGERTIP CONTROL OF IMPLEMENTS.

THE *SHOCK-ABSORBER* IS A FEATURE DESIGNED TO DAMPEN SHOCK LOADS AND PITCHING CAUSED BY THE WEIGHT OF IMPLEMENT DURING TRANSPORT FOR SAFE AND COMFORTABLE DRIVING ON ROAD.

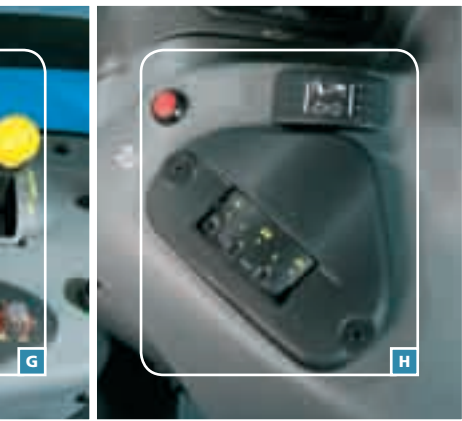

### HIGH-PERFORMANCE HYDRAULICS AND VERSATILITY OF AUXILIARY VALVES.

THE HYDRAULIC SYSTEM PROVIDES A MAXIMUM TOTAL FLOW RATE OF 33 GPM (125 LT/MIN).

THE SYSTEM FEATURES 5 AUXILIARY VALVES OF DIFFERENT TYPE; CONTROLLED BY *JOY-STICK* FOR FRONT LOADER USE (1); CONTROLLED BY LEVER (2); WITH ELECTROHYDRAULIC FLOW DIVERTER CONTROLLED BY BUTTON (3). THE FLOW DIVERTER ENABLES TO ALTERNATELY ACTIVATE THE RIGHT LIFTING ROD, THE TOP LINK OR THE VALVE ITSELF, THUS BRINGING THE NUMBER OF REAR AUXILIARY VALVES FROM 5 TO 7 FOR ENHANCED VERSATILITY AND INCREASED IMPLEMENT EFFICIENCY. > FIG. E - F



### HYDRA PTO: 2-SPEED PTO WITH HYDRAULIC ENGAGEMENT.

THE WET DISC CLUTCH, OPERATED BY A HYDRAULIC PUSHBUTTON (P) (FIG. E), ENABLES SMOOTH AND PROGRESSIVE ENGAGEMENT OF THE PTO.

THE 1<sup>3</sup>/<sub>8</sub> PTO PROVIDES TWO SPEEDS OF 540/1000 RPM.

### SPACIOUS CAB WITH ROOF-CONDITIONING.

BUILT ON A SILENT-BLOCK SUSPENDED PLATFORM. ACCURATE INTERIORS WITH CONTROLS ARRANGED IN ACCORDANCE WITH THE LATEST EUROPEAN STANDARDS. THE HEATING/VENTILATION/CLIMATE-CONDITIONING SYSTEM IS FITTED ON THE CAB OFFERING CONSIDERABLE BENEFITS FOR THE DRIVER'S COMFORT, SAFETY AND HEALTH. INTEGRATED IN THE CAB THERE IS ALSO A CLEAR SLIDING SUNROOF, PARTICULARLY USEFUL WHEN WORKING WITH FRONT LOADERS, TO PROTECT THE DRIVER FOR NIGHT WORK. > FIG. I

