

145-165 (T3)

# XTX

XtraSpeed





New **XTX(T3)**, superior performance  
in the **field** and on the **road**.

Developed from the TTX series, the XTX (T3) series is a new range of high-performance tractors that deliver less power than their bigger brothers and have a wheelbase of 108 inches. The range includes two models - XTX 145 and 165 -both equipped with 6.7L *BETA-POWER* TIER 3 engines.



Relying on their long experience, McCormick engineers developed the new *XtraSpeed* transmission, which is available with a choice of mechanical (STD version) or electronic (E/E-PLUS version) range shifting. The *XtraSpeed* transmission provides 32 speeds and four synchromesh ranges with hydraulic reverse power shuttle.

The electrohydraulically-engaged PTO provides two speeds of 540/1000 rpm, while the electronic power lift ensures a maximum lift capacity of 17,637 lbs. Optionally, the tractor may be equipped with a front power lift providing a lift capacity of 7,716 lbs.

The front axle, either rigid or with electronically-controlled suspensions, offers a steering angle of 55° for improved manoeuvrability.

The closed-centre hydraulics feature a variable-displacement pump with a flow rate of 29 gal/min and five hydraulic valves.

The cab - the same as fitted to the TTX series - is a four-post design with large, rear-hinged doors for all-round visibility. The air-conditioning, the pneumatic seat with multi-function armrest, the accurate automotive-style interiors and the optional hydraulic suspension system maximise the comfort of the cab.



## ENGINE

The new BETA-POWER 6-cylinder turbocharged engines mounted on the two XTX models feature 24 valves and a cylinder displacement of 6728 cm<sup>3</sup>. Both models are equipped with high-pressure electronic *COMMON-RAIL* fuel injection system and deliver respectively 145 and 162 HP (ISO).

The engine electronics ensure optimum and clean combustion for improved fuel efficiency and reduced emissions in line with TIER 3 regulations and provide a torque backup of approximately 40%. Combined with the engine electronics, the *Power Management* system allows an automatic increase of both the power and torque available at the PTO. The fully-tilting hood provides easy access to the engine for routine service and maintenance (*fig. A*).

## FRONT AXLE

The electronically-controlled suspended axle ensures high speeds on rough terrains and improves traction and manoeuvrability for enhanced comfort, safety and productivity, while keeping ground clearance unaltered (*fig. B*).



## TRANSMISSION

The 'XTRASPEED' electronic transmission provides 32 speeds in 4 ranges and 8 powershifts *under load in each range* with reverse power shuttle and offers a choice of mechanical (STD version) or electronic (E/E-PLUS version) range shifting.

The electronic version (E/E-PLUS) is controlled via joystick which allows all ranges and electronic powershift speeds to be engaged by simply pushing a button (*fig. C*).

The electronic system also features a "SKIP SHIFT" function allowing 'smart' shifting through all four ranges and a device named *AUTORODING* for automatic gear shifting during transport operations. The *AUTORODING* selects the right gear according to the engine load and rpm, allowing simple and smooth driving for maximised comfort and productivity and minimised consumption.

The transmission is also equipped with a hydraulic *REVERSE POWER SHUTTLE* (*fig. D*) which provides a total of 32 forward and 24 reverse speeds. A creeper unit can also be fitted as an option to achieve 48 forward and 40 reverse speeds.



## HYDRAULICS

The closed-centre hydraulic system with variable displacement pump provides a flowrate of 79 gal/min and ensures optimum operation of the five rear hydraulic valves available (fig. E). On the E-PLUS version, one of the auxiliary valves is controlled via the pushbuttons integrated into the joystick (1), while the other four are operated via the knobs located on the multi-function armrest (2 and 3) (fig. F). The multi-function armrest also houses the flow regulator and the timing control device, which can be regulated according to the task to be performed.



## ELECTRONIC POWER LIFT

With the main control (S) conveniently located in ergonomic position on the multi-function armrest (fig. F) and all main functions and regulations integrated into the right console (fig. G), the electronic power lift fitted on the E-Plus version allows for easy operation and fingertip control of the implements.

The Cat. 3 three-point linkage provides a lift capacity of 8000 kg.



## POWER TAKE-OFF

The wet disc clutch, hydraulically operated via a pushbutton (P) (fig. E), enables smooth and progressive engagement of the PTO.

The **POWER MANAGEMENT** system, which utilises the engine electronics, enables the power and torque available at the PTO to be automatically increased under load by approximately 10 HP, resulting in enhanced performance and productivity.



## CAB

The four-post cab with large, rear-hinged doors provides total all-round visibility and allows the operator to enter and exit with ease. It comes as standard with an air-conditioning system fitted on the roof, an adjustable steering wheel and a pneumatic seat with multi-function armrest on the E-Plus version.

The accurate automotive-style interiors and excellent sound-proofing make driving a pleasure.

The cab can be supplied with electronically-controlled hydraulic suspension as an option, which, combined with the front suspended axle supplied as standard, provides maximum driving comfort (fig. H).



	XTX 145 (T3) XTRASPEED	XTX 165 (T3) XTRASPEED
<b>ENGINE</b>		
TIER 3	BETAPOWER	BETAPOWER
ELECTRONIC HIGH PRESSURE COMMON RAIL	●	●
MAX. ENGINE POWER (ISO)	HP/KW 145 / 106	162 / 119
ENGINE POWER WITH POWER MANAGEMENT FOR PTO (ISO)	HP/KW 165 / 121	171 / 126
MAX. TORQUE (WITH POWER MANAGEMENT)	FT/LB (NM) 466/520 (632 (705))	538/551 (730 (747))
TORQUE BACKUP (WITH POWER MANAGEMENT)	40% (45%)	45% (40%)
DISPLACEMENT (CM <sup>3</sup> ) / CYLINDERS/VALVES	6.728 / 6 / 24	6.728 / 6 / 24
FUEL TANK CAPACITY	GAL (LITRES) 79 (300)	79 (300)
<b>CLUTCH</b>		
MULTI-DISC WET CLUTCH	●	●
<b>TRANSMISSION</b>		
XTRASPEED+ REV. SHUTTLE: 32FWD+24REV (8 POWERSHIFT SPEEDS) (STD VERSION)	●	●
XTRASPEED + CREEPER + REV. SHUTTLE: 48FWD+40REV (STD VERSION)	○	○
AUTORODING + REV. SHUTTLE: 32V + 24R (8 POWERSHIFT SPEEDS) (E/E-PLUS VERSION)	●	●
AUTORODING + CREEPER + REV. SHUTTLE: 48V + 40R (E/E-PLUS VERSION)	○	○
REVERSE POWER SHUTTLE: REVERSE SHUTTLE UNDER LOAD	●	●
ELECTROHYDRAULIC PARK LOCK	○	○
<b>POWER TAKE-OFF</b>		
WET MULTI-DISK PTO	●	●
ELECTROHYDRAULIC CONTROL	●	●
2 SPEEDS: 540/1000 RPM	●	●
<b>FRONT 4WD AXLE</b>		
RIGID TYPE	●	●
WITH ELECTRONICALLY-CONTROLLED HYDRAULIC SUSPENSIONS	○	○
MAX. STEERING ANGLE	55°	55°
TURNING RADIUS	IN (MM) 193 (4.900)	193 (4.900)
<b>HYDRAULICS</b>		
CLOSED-CENTRE CIRCUIT	●	●
HYDRAULIC FLOW	GAL (LTR)/MIN 29 (110)	29 (110)
MECHANICALLY / ELECTROHYDRAULICALLY-OPERATED AUXILIARY VALVES (STD / E VERSION) STD/OPT	3 / 1	3 / 1
ELECTROHYDRAULICALLY OPERATED AUXILIARY VALVES (E-PLUS VERSION) STD/OPT	4 / 5	4 / 5
<b>BRAKES</b>		
ANNULAR PISTON WET REAR BRAKES - 6 DISCS	●	●
AUTOMATIC 4 WD ENGAGEMENT ON BRAKING	●	●
"BRAKING BOOSTER SYSTEM" SERVO BRAKE	●	●
<b>POWER LIFT WITH "CAN BUS LIFT CONTROL"</b>		
ELECTRONICALLY OPERATED	●	●
FUNCTIONS: POSITION CONTROL, INTERMIX, FLOAT POSITION, SHOCK ABSORBER	●	●
MAX. LIFT CAPACITY	LBS (KG) 17,637 (8.000)	17,637 (8.000)
<b>CAB AND DRIVING SEAT</b>		
CAB WITH ELECTRONICALLY-CONTROLLED HYDRAULIC SUSPENSION	○	○
AIR-CONDITIONING	●	●
PNEUMATIC SUSPENSION SEAT (STD / E VERSION) - (E-PLUS VERSION)	(○) - (●)	(○) - (●)
<b>DIMENSIONS AND WEIGHTS</b>		
STD REAR TYRES	600/65 R38	600/65 R38
A - HEIGHT OVER CAB	IN (MM) 114 (2.900)	114 (2.900)
B - WHEELBASE	IN (MM) 108 (2.75)	108 (2.752)
C - MAX. LENGTH (WITH BALLAST WEIGHTS)	IN (MM) 205 (5.209)	205 (5.209)
D - GROUND CLEARANCE	IN (MM) 20 (505)	20 (505)
E - MIN. WIDTH	IN (MM) 98 (2.495)	98 (2.495)
TOTAL WEIGHT (WITHOUT BALLAST WEIGHTS)	LBS (KG) 14,330 (6.500)	14,330 (6.500)

Key: ● standard ○ option — not available

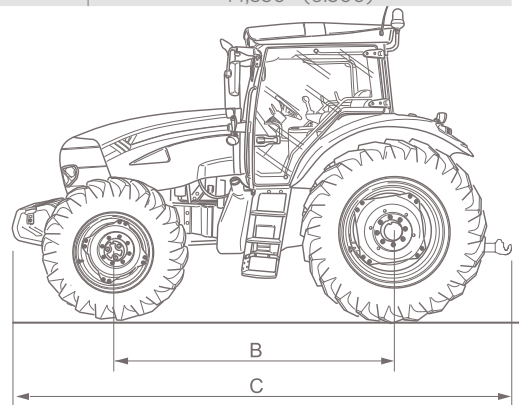
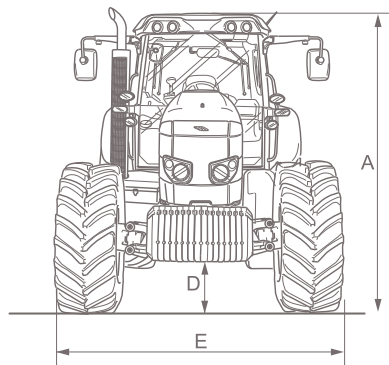

**McCormick International USA, Inc.**  
 2590 Breckenridge Blvd.  
 Duluth, GA 30096  
 866.327.6733  
 www.McCormickUSA.com

**McCORMICK™**  
 International USA, Inc.